

## 15

## Fancy

This engine is a fancy way of making a wobbler, thus the name Fancy. The main Column is made of free machining steel, the Crankshaft is steel, the Cylinder, Piston and Rod, Bushing and Pivot Shaft are brass. Aluminum was used for the Foot and Flywheel, although they would be better if made of steel.

For the COLUMN, chuck a piece of 3/4" diameter steel about 3-1/2" long in the 3-jaw and drill a center for the tailstock. Turn the 3/8" dowel and brighten up the 3/4" diameter for about 5/16". Starting at this 5/16" location, turn toward the chuck to a bright, smooth 5/8" diameter. Run a band of layout dye full length on the 5/8" diameter. Scribe lines at the 7/16", 1/2" and 1" points on the Column. Make these lines strong enough to be seen when rotating. Now turn each segment to the outline shown. Since there are three places at 5/8" diameter, it is easy to locate against the vise jaws for milling the flat. Lay out the 5/16" Crank and 1/8" Pivot holes. Machine these holes square with the flat faces.

Make the Drill Jig and locating Pin. Place the Jig over a 1/8" close-fitting pin in the pivot hole and hold against the locating pin as shown and drill the 1/16" port. Turn the Jig over to get the other hole. Note: one hole goes through and the other only 5/16" deep. Pick up the port hole centerline on the flat and transfer it around onto the side to locate the steam connection. Drill and tap for a 3/16" pipe. Make the Bearing and set in the Column with Loctite. Add an oil hole. Make the Foot and attach to the Column.

Make the CYLINDER from an accurate and square brass block 1 1/2" x 5/8" x 1-1/8". Lay out and centerpunch for the 3/8" bore and 1/8" pivot. Chuck in the 4-jaw and center with a center test indicator. Bore and ream the 3/8" diameter hole. Square up the bottom with a boring bar. On the last pass before reaming, make an undercut for reamer runout. Do not leave a tiny shoulder that the Piston might strike. Chuck the Cylinder in the 4-jaw using a small protector plate at the bore end. Center on the pivot point using a center test indicator. Check for squareness in the chuck using a dial indicator. Face, undercut and drill for the Pivot Pin. Make a brass Pivot Pin or Shaft 13/16" long. Thread the end 5-40. Insert a close-fitting aluminum pin in the 3/8" Cylinder bore. Apply a thin coat of flux around the end of the 1/8" Shaft and the 1/8" hole in the cylinder. Solder the shaft into the cylinder using a tiny bit of solder. Too much solder will keep the cylinder off its seat. The solder will not stick to the aluminum.

Make the PISTON as shown.

For the ROD, chuck a 1/4" rod in the 3-jaw with about 2" projecting. Drill a center hole with a 3/64" center drill and bring the tail center up for support. Turn the 1/8" diameter long enough to cut away the center later. Thread 5-40 with a tailstock die holder. Use parting cuts to bring to final dimensions. Hold the 1/8" diameter in a small V groove in the milling vise and mill to 1/8" thickness. Drill and ream for the Crank Pin. Insert the Piston/Rod assembly in the Cylinder. Place the drill jig over the Pivot Pin. Run a close-

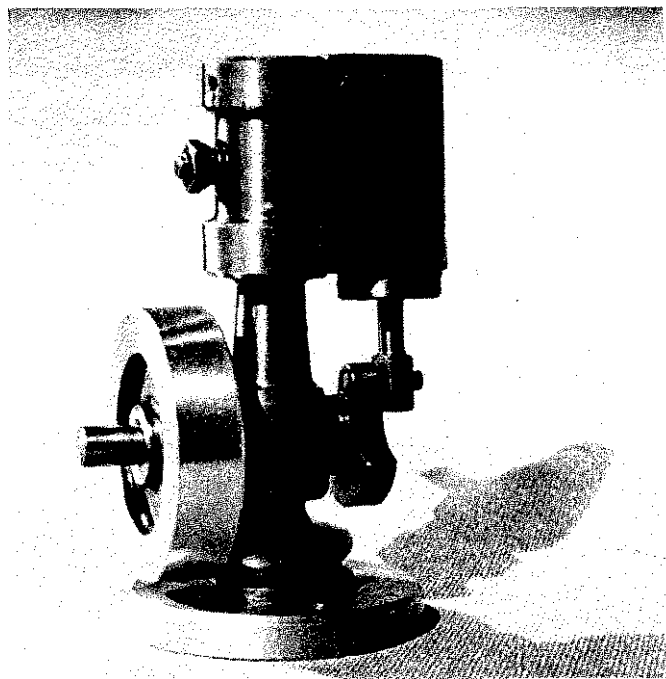
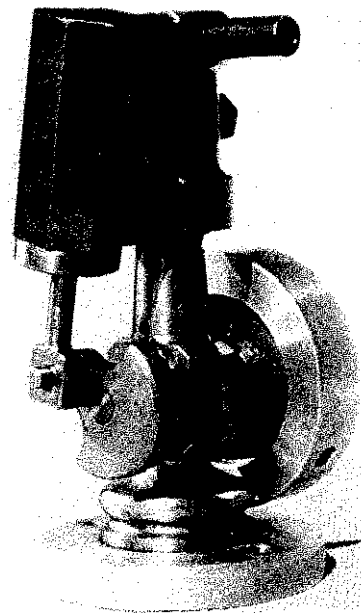

fitting 3/32" pin through the jig and Crank Pin hole. Then drill the 1/16" port hole in the Cylinder.

The CRANKSHAFT is simple and doesn't require much explanation. The shoulder on the Shaft helps square up the Disk at assembly.

The STEAM CONNECTION is for 3/16" plastic aquarium tubing. You may have other ideas for driving this engine.

The SPRING proportions shown are for one found in the odds-and-ends department, which seems to do a good job.

The FLYWHEEL is 1-1/4" diameter x 5/16" wide and fitted with a setscrew. In this case, the taps are too short to reach the center, so the setscrew is near the surface and the pressure transmitted to the Shaft by a loose pin in the tapdrill hole.

Assemble, lubricate and give your *Fancy* a trial run on 5 to 10 pounds of air.

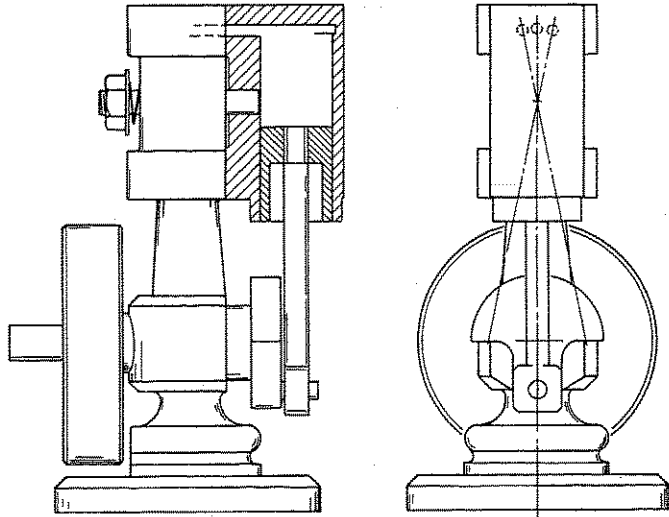
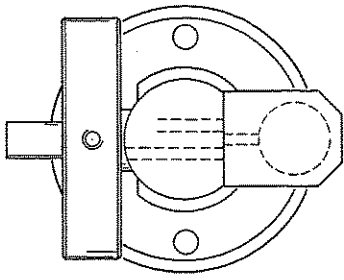

FANCY

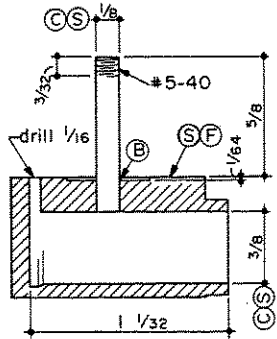
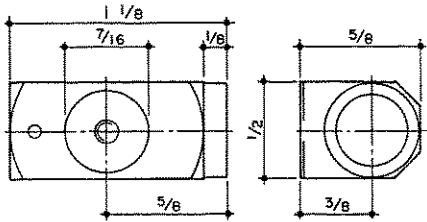

CYLINDER  
Brass

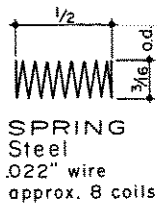

SPRING  
Steel  
.022" wire  
approx. 8 coils

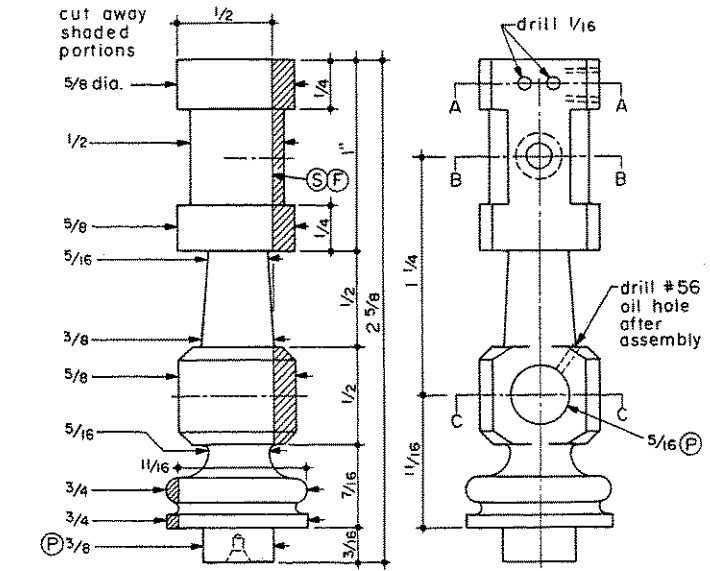

1 3/8 COLUMN Steel 3/16

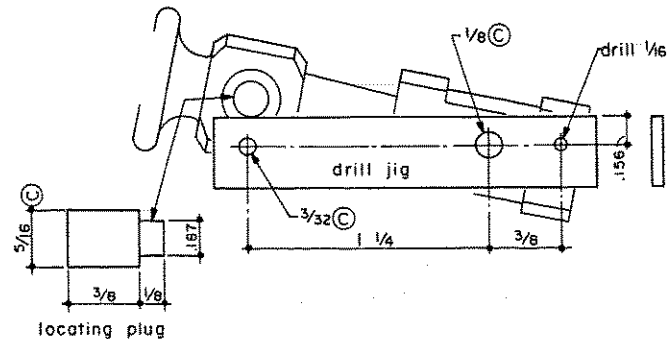
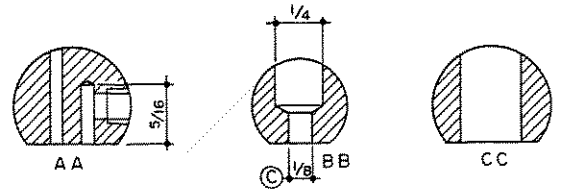

locating plug

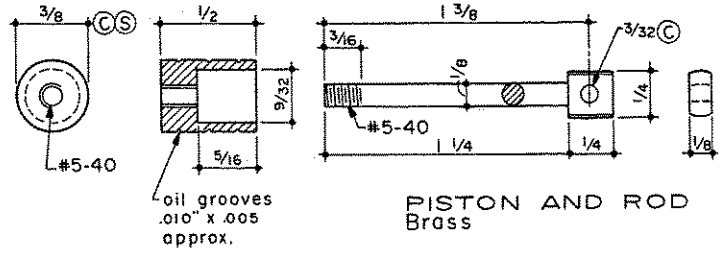

PISTON AND ROD  
Brass

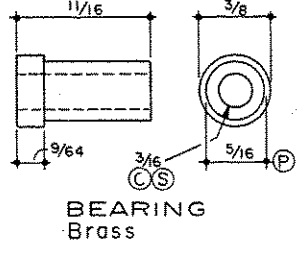

BEARING  
Brass

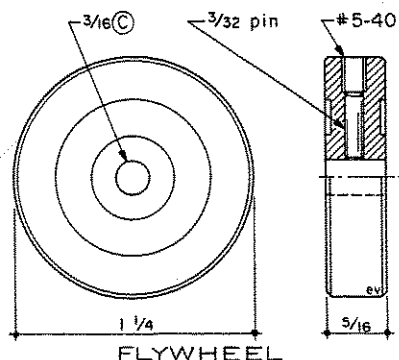

FLYWHEEL  
Any metal

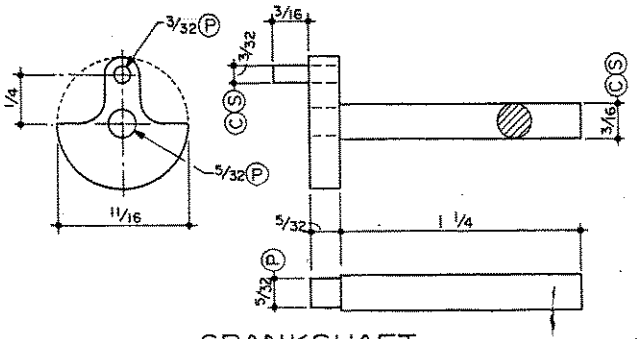

CRANKSHAFT  
Steel